



# RE-POWERING GUIDELINES

If replacing a Briggs & Stratton engine with a Briggs & Stratton engine, provide the original engine's model and type numbers to assure the correct replacement. If replacing a competitor's engine with a Briggs & Stratton engine, let the power level and features of the original engine plus the expected work cycle be a guide in selecting the correct replacement. Also consider these factors:

## 1. Engine Selection

Match the engine's performance and cost to your specific application to get the optimum performance at an affordable price. That means better value for you.

- **Vanguard™ OHV** (overhead valve) engines are maximum performance, cast iron cylinder sleeve engines.
  - select for continuous heavy duty applications.
- **INTEK™ PRO, Industrial Plus™ and I/C®** (Industrial/Commercial) engines are cast iron cylinder sleeve.
  - select for medium duty commercial, industrial and rental use.
- **INTEK™ and PowerBuilt™** engines are aluminum cylinder bore OHV engines.
  - select for general consumer use.
- **Standard** engines are aluminum cylinder bore, side valve engines.
  - select for general consumer use.

## 2. Safety Points

For many safe hours of operation, it is important to maintain the original engine's same power, starter type and position, fuel tank location, fuel line routing, muffler location, exhaust direction and muffler accessories (i.e., deflector, spark arrestor, etc.). Reinstall all guards, shields and safety devices. Replace missing, worn or damaged parts.

## 3. Horizontal Crankshaft Engines

- Compare overall engine size for possible mounting interference
- Match crankshaft's
  - Diameter "A"
  - Height "B" (distance from base to crankshaft center line)
  - Length "C" (distance from oil seal/cover's mounting face to end of crankshaft)
- Match crankshaft type, i.e., keyway, tapered or threaded
- Match crankcase cover's tapped holes for mounting accessories (if applicable)
- Match base mounting dimensions and bolt holes spacing

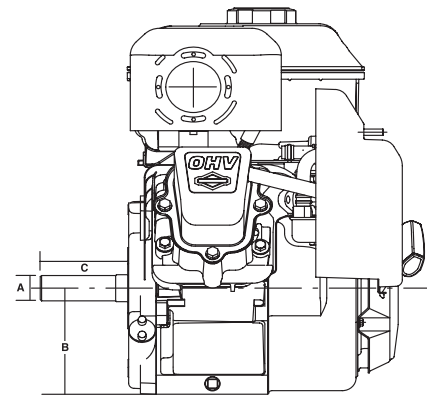

## 4. Vertical Crankshaft Engines

- Compare overall engine size for possible mounting interference
- Match starter type and starter grip position "A"
- Match crankshaft's
  - Diameter "B"
  - Keyway type "C"
  - Length "D" (distance from mounting face of sump - not oil seal - to end of crankshaft)
- Match mounting base dimensions and bolt holes spacing

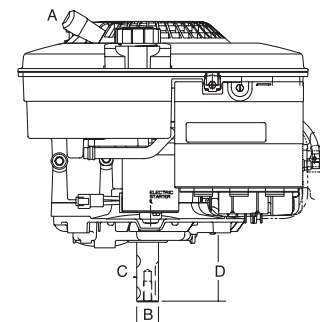

### WARNING

Briggs & Stratton does not approve or authorize the use of these engines on 3-wheel All Terrain Vehicles (ATVs), motor bikes, fun/recreational go-karts, aircraft products or vehicles intended for use in competitive events. Use of these engines in such applications could result in property damage, serious injury (including paralysis), or even death.

# SPECIFICATIONS OF SERVICE ENGINES

## LEGEND OF ABBREVIATIONS

<b>STARTER POSITION:</b>	Number shown is “o’clock” position of rewind starter. Spark plug is considered to be the 12 o’clock position.
<b>OIL FILLER &amp; DRAIN:</b>	“CS” – carburetor side, “OC” – opposite carburetor, “D” – dual (both sides), “T” (Three sided).
<b>GOVERNOR:</b>	“AV” – air vane, “M” – mechanical, “E” – electronic.
<b>CONTROLS:</b>	“MF” – manual friction, “R” – remote, “AG” – adjustable for a constant speed operation, “FC” – fixed speed control.
<b>GROUND WIRE TERMINAL:</b>	May be used with stop switch in remote location.
<b>ACCESSORY MTG. BOSS or FLANGE MOUNTING:</b>	Tapped holes in crankcase cover used to fasten clutch brackets, belt guards, etc.
<b>DIMENSION:</b>	Distance from end of crankshaft to one of the points listed below: (a) Oil seal on plain bearing horizontal crankshaft engines. (b) Mounting face of sump on vertical crankshaft engines. (c) Flange mounting face on horizontal crankshaft engines.
<b>SHIPPING WEIGHT:</b>	Gross Domestic Shipping Weight.

ALL POWER RATINGS SHOWN IN THIS CATALOG ARE SUBJECT TO THE FOLLOWING:

The gross power rating labels for individual gas engine models is labeled in accordance with SAE (Society of Automotive Engineers) code J1940 (Small Engine Power & Torque Rating Procedure), and rating performance has been obtained and corrected in accordance with SAE J1995 (Revision 2002-05). Torque values are derived at 3060 RPM; horsepower values are derived at 3600 RPM. Actual gross engine power will be lower and is affected by, among other things, ambient operating conditions and engine-to-engine variability. Given both the wide array of products on which engines are placed and the variety of environmental issues applicable to operating the equipment, the gas engine will not develop the rated gross power when used in a given piece of equipment (actual “on-site” or net power). This difference is due to a variety of factors including, but not limited to, accessories (air cleaner, exhaust, charging, cooling, carburetor, fuel pump, etc.), application limitations, ambient operating conditions (temperature, humidity, altitude), and engine-to-engine variability. Due to manufacturing and capacity limitations, Briggs & Stratton may substitute an engine of higher rated power for this Series engine.



## YOUR KEY TO THE WORLD'S FINEST ENGINES

This chart explains the unique Briggs & Stratton numerical model designation system. It is possible to determine most of the important mechanical features of the engine by merely knowing the model number. Here is how it works:

- A. The first one or two digits indicate the approximate CUBIC INCH DISPLACEMENT.
- B. The first digit after the displacement indicates the BASIC DESIGN SERIES, relating to cylinder construction, ignition, general configuration, etc.
- C. The second digit after the displacement indicates ORIENTATION OF CRANKSHAFT.
- D. The third digit after the displacement indicates TYPE OF BEARINGS, and whether or not the engine is equipped with REDUCTION GEAR or AUXILIARY DRIVE.
- E. The last digit indicates the TYPE OF STARTER.

### BRIGGS & STRATTON MODEL NUMBERING SYSTEM

A	FIRST DIGIT AFTER DISPLACEMENT B	SECOND DIGIT AFTER DISPLACEMENT C	THIRD DIGIT AFTER DISPLACEMENT D	FOURTH DIGIT AFTER DISPLACEMENT E
CUBIC INCH DISPLACEMENT	BASIC DESIGN SERIES	CRANKSHAFT ORIENTATION	PTO BEARING, REDUCTION GEAR, AUXILIARY DRIVE, LUBRICATION	TYPE OF STARTER
2	0	0 to 4 - Horizontal Shaft	0 - Plain Bearing/DU Non-Flange Mount	0 - Without Starter
5	1	5 to 9 - Vertical Shaft		1 - Rope Starter
6	2	A to G - Horizontal Shaft	1 - Plain Bearing Flange Mounting	2 - Rewind Starter
8	3	H to Z - Vertical Shaft	2 - Sleeve Bearing Flange Mounting Splash Lube	3 - Electric Starter Only 110 or 230 Volt Gear Drive
9	4		3 - Ball Bearing Flange Mounting Splash Lube	4 - Electric Starter/110 or 230 Volt Gear Drive with Alternator
11	5		4 - Ball Bearing Flange Mounting Pressure Lubrication	5 - Electric Starter Only 12 or 24 Volt Gear Drive
12	6		5 - Plain Bearing Gear Reduction (6 to 1) CCW Rotation Flange Mounting	6 - Alternator Only
13	7		6 - Ball Bearing Gear Reduction (2 to 1) CCW Rotation	7 - Electric Starter 12 or 24 Volt Gear Drive with Alternator
15	8		7 - Plain Bearing Pressure Lubrication	8 - Vertical Pull Starter or Side Pull Starter
16	9		8 - Plain Bearing Auxiliary Drive (PTO) Perpendicular to Crankshaft	9 - Mechanical Starter
18	A to Z		9 - Plain Bearing Auxiliary Drive Parallel to Crankshaft	A - Electric Starter 12 or 24 Volt Gear Drive with Alternator and Inverter
19			A - Plain Bearing Pressure Lubrication Without Oil Filter	
20				
21				
22				
23				
24				
25				
28				
29				
30				
31				
32				
35				
38				
40				
42				
43				
44				
46				
47				
52				
54				
58				
61				

EXAMPLE - To identify Model 303447:

<u>30</u>	<u>3</u>	<u>4</u>	<u>4</u>	<u>7</u>
30 Cubic Inch	Design Series 3	Horizontal Shaft	Ball Bearing Flange Mounting Pressure Lubrication	Electric Starter 12 or 24 Volt Gear Drive with Alternator

**TYPE 1234-01**, The type number identifies the engines mechanical parts, color of paint, decals, governed speed, and Original Equipment Manufacturer.

**CODE 01061201**, The code is the manufacturing date and is read as follows:

<u>01</u>	<u>06</u>	<u>12</u>	ASSEMBLY LINE AND MANUFACTURING PLANT
YEAR	MONTH	DAY	
01	06	12	01

## BRIGGS & STRATTON ENGINE OWNER WARRANTY POLICY

Effective 12/06

### LIMITED WARRANTY

Briggs & Stratton Corporation will repair or replace, free of charge, any part(s) of the engine that is defective in material or workmanship or both. Transportation charges on product submitted for repair or replacement under this warranty must be borne by purchaser. This warranty is effective for the time periods and subject to the conditions stated below. For warranty service, find the nearest Authorized Service Dealer in our dealer locator map at [www.briggsandstratton.com](http://www.briggsandstratton.com), or by calling 1-800-233-3723.

There is no other express warranty. Implied warranties, including those of merchantability and fitness for a particular purpose, are limited to one year from purchase, or to the extent permitted by law and all implied warranties are excluded. Liability for incidental or consequential damages are excluded to the extent exclusion is permitted by law. Some states or countries do not allow limitations on how long an implied warranty lasts, and some states or countries do not allow the exclusion or limitation of incidental or consequential damages, so the above limitation and exclusion may not apply to you. This warranty gives you specific legal rights and you may also have other rights which vary from state to state and country to country.

### WARRANTY TERMS\*\*

	Consumer Use	Commercial Use
Vanguard™	2 years	2 years
Extended Life Series™, I/C®, Intek I/C®, Intek Pro™	2 years	1 year
Kerosene fuel operated Engines	1 year	90 days
All other Briggs & Stratton Engines	2 year	90 days

\*\* Engines used on Home Standby Generator applications are warranted under consumer use only. This warranty does not apply to engines on equipment used for prime power in place of a utility. **Engines used in competitive racing or on commercial or rental tracks are not warranted.**

The warranty period begins on the date of purchase by the first retail consumer or commercial end user, and continues for the period of time stated in the table above. "Consumer use" means personal residential household use by a retail consumer. "Commercial use" means all other uses, including use for commercial, income producing or rental purposes. Once an engine has experienced commercial use, it shall thereafter be considered as a commercial use engine for purposes of this warranty.

**NO WARRANTY REGISTRATION IS NECESSARY TO OBTAIN WARRANTY ON BRIGGS & STRATTON PRODUCTS. SAVE YOUR PROOF OF PURCHASE RECEIPT. IF YOU DO NOT PROVIDE PROOF OF THE INITIAL PURCHASE DATE AT THE TIME WARRANTY SERVICE IS REQUESTED, THE MANUFACTURING DATE OF THE PRODUCT WILL BE USED TO DETERMINE THE WARRANTY PERIOD.**

